



BASICline

USE INSTRUCTION
RS5e - RS40e





Contents

| | Page |
|--|-------|
| Technical data | 3 |
| Security instructions | 4 |
| Assembling, Application, Maintenance | 5 |
| Putting into operation | 6 |
| Drawing of drilling mechanism RS5e | 7 |
| Drawing of electrical system RS5e | 8 |
| Spare parts list RS5e | 9 |
| Drawing of drilling mechanism RS10 | 10 |
| Drawing of drilling unit RS10 | 11 |
| Drawing of electrical system RS10 | 11 |
| Spare parts list RS10 | 12/13 |
| Drawing of drilling mechanism RS25e | 14 |
| Drawing of drilling unit RS25e | 15 |
| Drawing of electrical system RS25e | 15 |
| Spare parts list RS25e | 16/17 |
| Drawing of drilling mechanism RS40e | 18 |
| Drawing of drilling unit RS40e | 19 |
| Drawing of electrical system RS40e | 19 |
| Spare parts list RS40e | 20/21 |
| Connection diagramm RS10, RS25e, RS40e | 22 |
| Guarantee + Declaration of conformity | 23 |



Technical data



| Technical data | RS5e | RS10 | RS25e | RS40e |
|---------------------------------|-------------------|-------------------|--------------------------|-------------------------|
| Article no. | 108 006 RS | 108 001 RS | 108 005 RS | 108 004 RS |
| Mag. clamping force: | 10.000 N | 10.000 N | 13.000 N | 13.000 N |
| Power consumption: | 1.200 Watt | 1.120 Watt | 1.200 Watt | 1.840 Watt |
| Gears: | 1 gear | 1 gear | 2 gear | 2 gear |
| Rotation speeds r.p.m.: | 140 - 350 r.p.m. | 450 r.p.m. | 100-250 / 180-450 r.p.m. | 60-140 / 200-470 r.p.m. |
| Electrical rotation controller: | ✓ | | ✓ | ✓ |
| Torque controller: | | | | ✓ |
| Right/left-handed rotation: | | | ✓ | ✓ |
| Height: | 182,0 mm | 413,0 - 548,0 mm | 408,0 - 598,0 mm | 450,0 - 640,0 mm |
| Width: | 160,0 x 80,0 mm | 160,0 x 80,0 mm | 190,0 x 90,0 mm | 190,0 x 90,0 mm |
| Weight: | 11,0 kg | 13,0 kg | 18,0 kg | 24,0 kg |
| Lift: | 38,0 mm | 135,0 mm | 190,0 mm | 190,0 mm |
| Adapter: | Weldon 19,0 mm | Weldon 19,0 mm | Morse taper MT 2 | Morse taper MT 3 |
| Core drills: | Ø 12,0 - 35,0 mm | Ø 12,0 - 35,0 mm | Ø 12,0 - 60,0 mm | Ø 12,0 - 100,0 mm |
| Drill chuck: | | 1,0 - 13,0 mm | 3,0 - 16,0 mm | 3,0 - 16,0 mm |
| Twist drills DIN 338: | | max. Ø 10,0 mm | max. Ø 13,0 mm | max. Ø 16,0 mm |
| Twist drills DIN 1897: | | max. Ø 13,0 mm | max. Ø 16,0 mm | max. Ø 16,0 mm |
| Twist drills DIN 345: | | | max. Ø 20,0 mm | max. Ø 31,5 mm |
| Cutting depth core drills: | 30,0 mm | 30,0 mm | 30,0 / 55,0 mm | 30,0 / 55,0 mm |
| Input voltage: | 220 – 240 V | 220 – 240 V | 220 – 240 V | 220 – 240 V |
| Conformity with: | VDE, CEE | VDE, CEE | VDE, CEE | VDE, CEE |
| Moveable field: | | | | +/- 7,5 mm |
| Turn field: | | | | +/- 20° |
| Thread cutting: | | | ✓ | ✓ |



| Accessoires | RS5e | RS10 | RS25e | RS40e |
|-------------|------------------------------------|--|--|--|
| | Carrying bag incl. 2 plastic boxes | Plastic tool case | Plastic tool case | Plastic tool case |
| | Allen key | Allen key | Drill drift | Drill drift |
| | Safety belt | Safety belt | Safety belt | Safety belt |
| | | Drill chuck, No.108 116 1,0 - 13,0 mm | Drill chuck, No.108 117 3,0 - 16,0 mm | Drill chuck, No.108 117 3,0 - 16,0 mm |
| | Coolant bottle + sprayer | Coolant bottle + sprayer | Coolant bottle + sprayer | Coolant bottle + sprayer |
| | | Drill chuck adapter | Spike cone MT 2 / B16 | Spike cone MT 3 / B16 |
| | | | Protective work gloves + Safety goggles | Protective work gloves + Safety goggles |
| | | Arbor holder, Art. no. 108 159 | EasyLock Br. 108 317 | EasyLock Br. 108 318 |

Subject to alterations and errors!



Attention: Please read this manual carefully before using the drilling unit

The drilling units may only be used according to their determination. The use of the drilling unit as a lifting magnet is dangerous and absolutely inadmissible. The use for another purpose than what is determined endangers people and the machine.

Please note also the following safety instructions for electric tools.

Attention: Before the use of electric tools please note the following basic safety instructions to avoid electric shock, injuries and fire. Read and follow these instructions before using the electric tool.

1. Keep your working area tidy.
A working area that is not cleared up causes danger of accidents.
2. Consider external influences.
Do not expose electric tools to rain. Do not use electric tools in damp or wet surroundings. Good lighting is important.
Do not use electric tools near inflammable fluids or gases.
3. Protect yourself from electric shock.
Avoid body contact to earthed parts like pipes, radiators, ovens, fridges.
4. Keep away from children.
Do not let other people touch the tool or the cable - keep them from your working area.
5. Keep your electric tools in a safe place.
Unused tools should be kept in a dry, closed space out of the reach of children.
6. Do not overload your electric tools.
You will work better and safer within the indicated power range.
7. Use the right tool.
Do not use tools weak in power for heavy strains. Do not use tools for purposes other than determined, e.g. do not use a circular saw for felling a tree or cutting branches.
8. Use suitable working clothes.
Do not wear loose clothing or jewelry. They could be caught by moving parts of the tool.
If you are working outdoors it is recommendable to wear rubber gloves and non-slipping shoes. If you have long hair wear a hair-net.
9. Use protective goggles.
Also use a breathing mask when carrying out work that produces dust.
10. Do not use the cable for other purposes.
Do not use the cable for carrying the tool and do not use it to pull the plug out of the socket.
Protect the cable from heat, oil and cutting edges.
11. Secure your workpiece.
Use a fastening device or a vise to fix the workpiece.
The workpiece is better fixed than by hand and it makes it possible to use the tool with both hands.
12. Do not lean too far over the machine.
Take care to keep a normal position. You should have a secure standing position and you should keep your balance.
13. Maintain your tools carefully.
Keep your tools sharp and clean - working with them will be better and safer. Follow the maintenance instructions and indications concerning the replacement of tools. Check the cable regularly and in case of damage let it replace by an expert. Also check extension cables regularly and replace them if they are damaged. Keep handles dry and free from oil and grease.
14. Pull the plug out of the socket.
If you do not use the machine, before maintenance, while changing tools like saw blades, drills or any kind of machine tools.
15. Remove tool keys.
Before turning the machine on, make sure that all keys and adjustment tools are removed.
16. Avoid turning on the machine inadvertently.
Do not carry tools that are plugged in with your finger on the switch. Make sure the switch is on „off“ position while plugging in the tool.
17. Extension cables outdoors.
Only use extension cables that are authorized to be used outdoors and that are accordingly marked.
18. Always take care.
Control your work. Be sensible and do not use the tools when you have difficulties in concentrating.
19. Check if your appliance shows damages.
Before further use of the tool please check if safety appliances or damaged parts are working correctly. Check if the moving parts function correctly, if they move without problems, if no parts are broken, if all other parts are fixed correctly and if all other conditions that influence the working of the machine are fulfilled. If the use instruction does not say otherwise the damaged safety appliances and parts should be either repaired or replaced correctly. Damaged switches have to be replaced. Do not use tools where the switches cannot be set to „on“ or „off“.
20. Attention!
For your own safety only use accessories and attachments that are indicated in the use instruction or are offered in the according catalogue.
The use of tools or accessories other than recommended by the use instruction may be dangerous.
21. Repairs should be carried out only by experts
Electric tools are subject to the according safety regulations.
Repairs may only be carried out by an expert, otherwise the user runs the risk of accidents.

Please keep these instructions carefully.

Assembling

The magnetic drilling units are supplied with a high powered electromagnet as well as a reclosure preventing device for the drilling mechanism. The magnetic drilling units correspond to protection class I with conductor according to IEC 745. The drilling mechanisms that have been developed according to DIN VDE 0740 and IEC 745-1 are radio screened according to EN 55014 and EN 61000 and are designed for continuous operation: It is possible that the sound level exceeds 85 dB (A). In this case special sound protection is necessary for the user. Indications concerning the sound level of the drilling units are based on DIN 45 649 part 2, DIN 45 635 part 21 and DIN EN 27 574 (ISO 7574).

The precise adjustment allows an exact adjustment of the drilling tool within the movable field. The adjustable dovetail guidance with wear resisting brass guide beads allows a precise guidance of the drilling mechanism. This ensures light and regular feed. The drill feed is made manually with the handle.

Application of the drilling unit RS5e, RS10, RS25e, RS40e

The magnetic drilling units are designed for drilling and thread cutting (with reversing adapter) on workpieces with magnetic properties for horizontal, vertical or overhead work. These drilling units with their rectangular footing are especially adapted for drilling in structural steel. The drilling unit should be placed on an even spot on the workpiece. This spot may be unworked. Loose rust and cinder as well as varnish and flat coats have to be removed. If material thinner than 1/2" (12.0 mm) is drilled, a steel plate should be put under the workpiece to reinforce the magnetic power.

Never put the running magnetic drilling unit on insulating material (e.g. wood, concrete, etc.). The insufficient heat dissipation may cause overheating and destruction of the electromagnet. Be aware that the magnetic clamping force is not retained after an interruption of the electricity supply (power failure, pulling of the plug). The magnetic drilling units may not be used while arc welding is carried out on the workpiece. The welding current could damage the magnetic drilling unit. The magnetic drilling units have a locking device that prevents the machine from starting automatically. This locking device ensures that after pressing the red switch only the electromagnet is supplied with electricity.

The drilling mechanism is only supplied with electricity after pressing the green switch. It is only now that the drilling mechanism can work.

If the electricity supply is interrupted (caused for example by a damaged supply line or by pressing the red switch) the drilling mechanism remains without electricity even after the interruption is over or the red switch has been pressed again. To supply the drilling mechanism with electricity again you have to press the green switch once more. The drilling mechanism starts working.

Maintenance

Damaged parts have to be replaced by original spare parts. All gliding surfaces have to be oiled quarterly after cleaning. Lateral play can be balanced by adjusting the set screws. For optimal cooling the ventilating valves of the drilling mechanism have to be kept free from dirt and dust. Please note that electric devices may only be repaired, maintained and checked by electric experts, as improper repairs can endanger the user!

For ordering spare parts it is necessary to indicate our order number or to send us a sample and indicating the serial number, machine type and voltage.



Before putting into operation

Plug the cable into a suitable supply. Check the correct voltage!

If you are using an extension cable please check if it is suitable for the machine's rated input power!

Attention: For vertical and overhead drilling work it is absolutely necessary to wear the enclosed safety belt.

Putting into operation

Position the drill bit over the drilling point. Switch the magnetic drilling unit on by pressing the red switch. The magnetic field that is created keeps the drilling unit clamped to the workpiece. Before drilling check if the magnetic drilling unit clamps safely to the workpiece.

Magnetic drilling units with the possibility of precise adjustment (see technical data) allow an exact positioning of the drill bit even after the electromagnet has been switched on. For this it is necessary to loosen the lever of the precise adjustment device. The drilling mechanism can now be moved and adjusted on the electromagnet. After the drill bit has been adjusted the lever is fastened and the adjusted position is fixed. With machines with more than one gear adjust the rotation speed of the engine according to the tool to be used.

Attention: Change rotation speeds only when the drilling mechanism is not working! The speeds are indicated by a single or double symbols on the changeover switch. The changeover can be helped by gently turning the work spindle by hand. For drill drive units which also have electronic speed controllers, the speed and power (torque) can be continuously adjusted at the corresponding controller on the drill drive unit.

Note: also read and follow the additional information provided under Drill drive type RS 40e.

For drill drive units with electronic speed controllers, the speed is adjusted at the corresponding set wheel on the control panel of the drill stand. For drill drives with the forward and reverse feature (types RS 40e only) the direction is changed via the black switch on the control panel of the drill stand. Position „R“ is for clockwise and Position „L“ is for the anticlockwise rotation. Note: The direction of rotation must only be changed when the drill drive is switched off. The switch is for turning on the drilling mechanism (green light up ON).

Please note: The drilling mechanism can only be started after the electromagnet has been switched on. Drill feed is made manually by moving the handles. To avoid overloading of the magnetic drilling unit or to avoid premature wear of the tool it is necessary to adjust the drilling pressure. After each cut chips and/or drilling cores have to be removed. Cooling/lubrication has to be made according to the tool used. Please take care to use not more cooling/lubrication paste than necessary and that it does not get into the drilling mechanism.

After usage the magnetic drilling units should be stored in a vertical position so that the gear oil may spread evenly.

Drawing of drilling mechanism RS5e

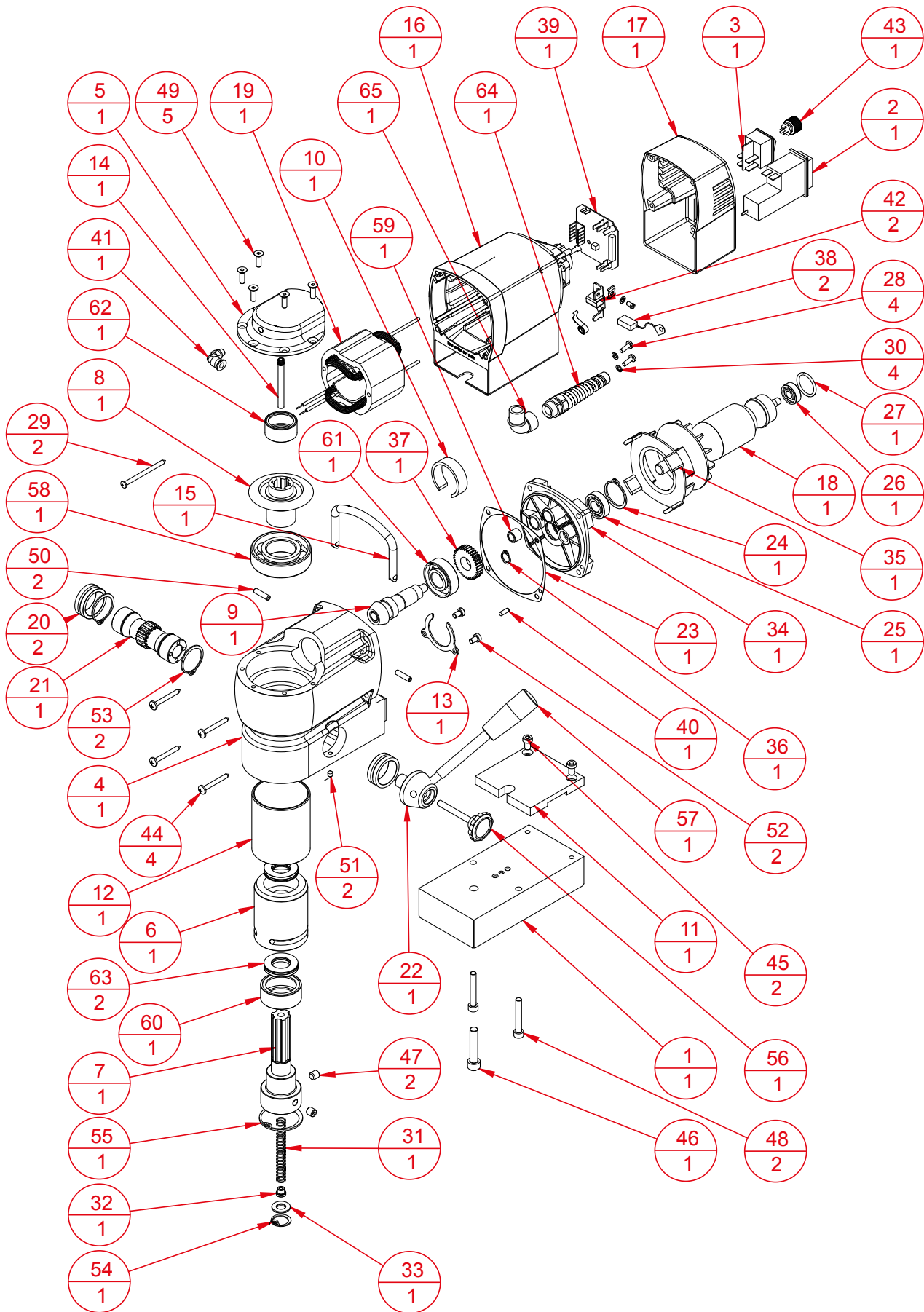

Drawing of electrical system RS5e

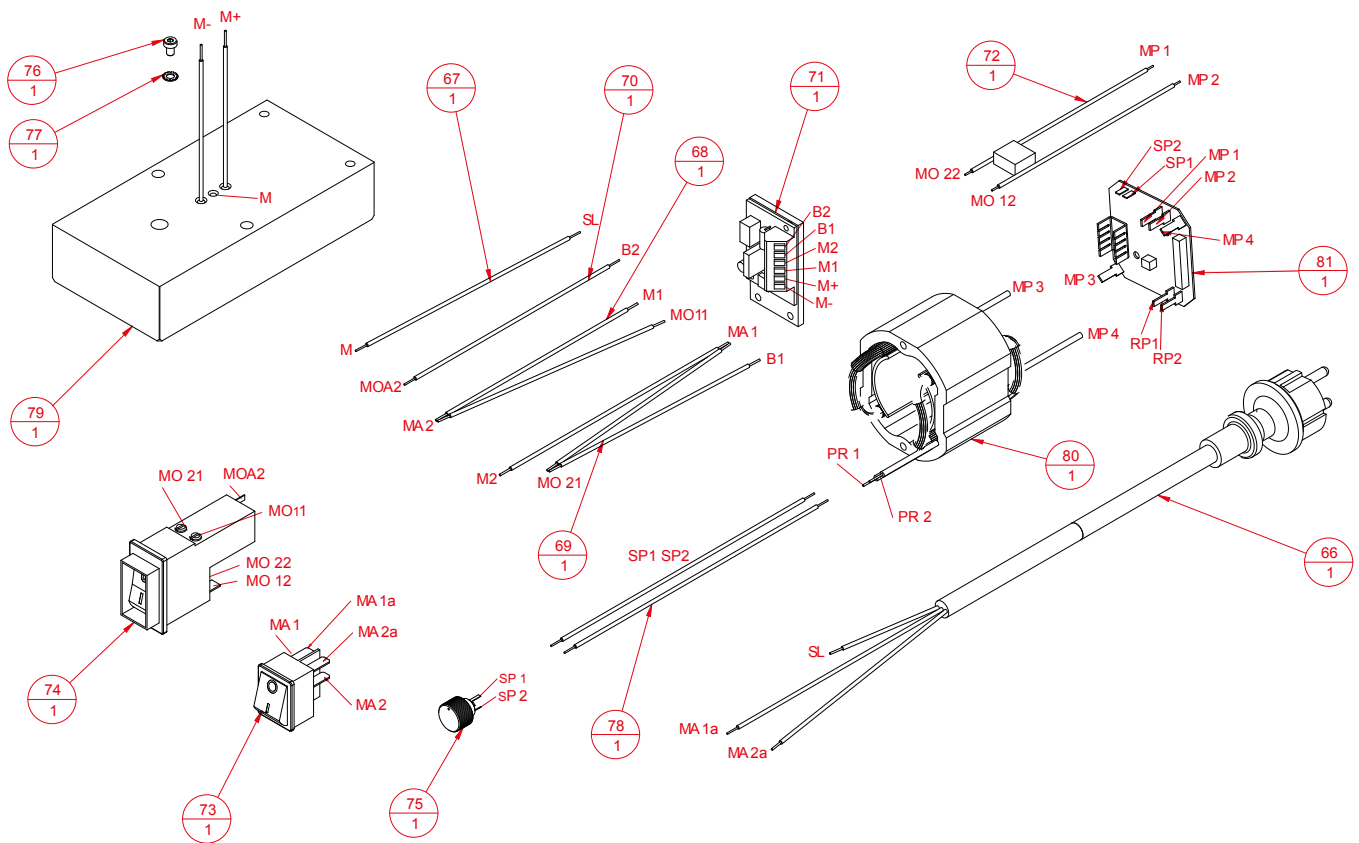

Drilling mechanism RS5e

| Pos. | Description | Article no. | Quantity |
|------|-----------------------------------|-------------|----------|
| 1 | Magnet | 611 1 101 | 1 |
| 2 | Motor switch RS5e | 611 0 401 | 1 |
| 3 | Magnet switch RS5e | 611 0 402 | 1 |
| 4 | Gear box | 611 0 501 | 1 |
| 5 | Cap Gear box | 611 0 502 | 1 |
| 6 | Gear bushing | 611 0 503 | 1 |
| 7 | Spindle | 611 0 504 | 1 |
| 8 | Gear 33Z + spline | 611 0 505 | 1 |
| 9 | Gear 11Z + axle | 611 0 506 | 1 |
| 10 | Distance tube bearing | 611 0 507 | 1 |
| 11 | Intermediate plate | 611 0 508 | 1 |
| 12 | Sliding bushing | 611 0 509 | 1 |
| 13 | Locking plate | 611 0 511 | 1 |
| 14 | Coolant pipe | 611 0 514 | 1 |
| 15 | Handle | 611 0 515 | 1 |
| 16 | Motor casing | 611 0 516 | 1 |
| 17 | Motor cover | 611 0 517 | 1 |
| 18 | Rotor | 611 0 518 | 1 |
| 19 | Pol ring | 611 0 519 | 1 |
| 20 | Bearing bowl | 611 0 303 | 2 |
| 21 | Pinion shaft | 611 1 312 | 1 |
| 22 | Adapter for handle | 611 1 313 | 1 |
| 23 | Gasket for gear box | 611 1 501 | 1 |
| 24 | Safety ring DIN 471 - 28 x 1.5 | 611 1 524 | 1 |
| 25 | Ball bearing 6001-2Z | 611 1 525 | 1 |
| 26 | Ball bearing 608 2Z | 611 1 526 | 1 |
| 27 | O-ring 22 x 2.5 | 611 1 527 | 1 |
| 28 | Thread groove screw ZM 4.0 x 12.0 | 611 1 530 | 4 |

Drilling mechanism RS5e

| Pos. | Description | Article no. | Quantity |
|------|-----------------------------|-------------|----------|
| 29 | Screw DIN 7981 3.9 x 60 | 611 1 531 | 2 |
| 30 | Spring washer B4 corrugated | 611 1 533 | 4 |
| 31 | Spring | 611 1 705 | 1 |
| 32 | Spring bracket | 611 1 707 | 1 |
| 33 | Plate | 611 1 710 | 1 |
| 34 | Gear bearing sign | 611 2 505 | 1 |
| 35 | Air conduction ring | 611 2 507 | 1 |
| 36 | Safety ring DIN 471-11 x 1 | 611 2 519 | 1 |
| 37 | Stud wheel 34.0 x 8.0 | 611 2 522 | 1 |
| 38 | Carbon brush | 611 2 551 | 2 |
| 39 | Circuitboard | 611 2 553 | 1 |
| 40 | Cylindrical pin DIN7 4 x 12 | 611 3 215 | 1 |
| 41 | Elbow connection coolant | 611 3 515 | 1 |
| 42 | Brush holder compl. | 611 1 528 | 2 |
| 43 | Resistance for recolution | 611 4 405 | 1 |
| 44 | DIN7981 - 4.8 x 38 | 611 9 014 | 4 |
| 45 | DIN 7984 - M6 x 10 | 611 9 017 | 2 |
| 46 | DIN912 - M8 x 40 | 611 9 035 | 1 |
| 47 | DIN913 - M8 x 8 | 611 9 043 | 2 |
| 48 | DIN 912 - M6 x 40 | 611 9 068 | 2 |
| 49 | DIN 7991 - M5 x 16 | 611 9 070 | 5 |
| 50 | DIN 913 - M5 x 20 | 611 9 073 | 2 |
| 51 | DIN914 - M5 x 6 | 611 9 077 | 2 |
| 52 | DIN 7984 - M5 x 8 | 611 9 078 | 2 |
| 53 | DIN 471 - 27 x 1.2 | 611 9 304 | 2 |
| 54 | DIN 472 - 19 x 1 | 611 9 308 | 1 |
| 55 | DIN 472 - 42 x 1.75 | 611 9 313 | 1 |
| 56 | Handle 50.0 mm | 611 9 808 | 1 |
| 57 | Handle | 611 9 814 | 1 |
| 58 | Bearing 7206 BE | 611 9 830 | 1 |
| 59 | Needle bush HK 0810 | 611 9 833 | 1 |
| 60 | Needle bush 4905 | 611 9 840 | 1 |
| 61 | Bearing 7203 BE | 611 9 841 | 1 |
| 62 | Needle bearing 2516 | 611 9 846 | 1 |
| 63 | Bearing AXK 2035 | 611 9 848 | 2 |
| 64 | Screwed cable gland | 611 9 854 | 1 |
| 65 | Elbow union | 611 9 855 | 1 |

Electrical system RS5e

| Pos. | Description | Article no. | Quantity |
|------|---|-------------|----------|
| 66 | Main cable | 611 1 410 | 1 |
| 67 | Ground cable magnet | 611 1 411 | 1 |
| 68 | Cables motor switch-magnet switch-plate | 611 1 412 | 1 |
| 69 | Cables motor switch-magnet switch-plate-plate | 611 1 413 | 1 |
| 70 | Cables motor swittch-plate | 611 1 414 | 1 |
| 71 | Circuitboard | 611 1 404 | 1 |
| 72 | Cables capacitor motor | 611 0 403 | 1 |
| 73 | Magnet switch RS5e | 611 0 402 | 1 |
| 74 | Motor switch RS5e | 611 0 401 | 1 |
| 75 | Resistance for recolution | 611 4 405 | 1 |
| 76 | DIN 7984 - M4 x 6 | 611 9 016 | 1 |
| 77 | DIN 6797 - M4 | 611 9 402 | 1 |
| 78 | Ground cable magnet | 611 1 411 | 1 |
| 79 | Magnet | 611 1 101 | 1 |
| 80 | Pol ring | 611 0 519 | 1 |
| 81 | Circuitboard | 611 2 553 | 1 |

Drawing of drilling mechanism RS10

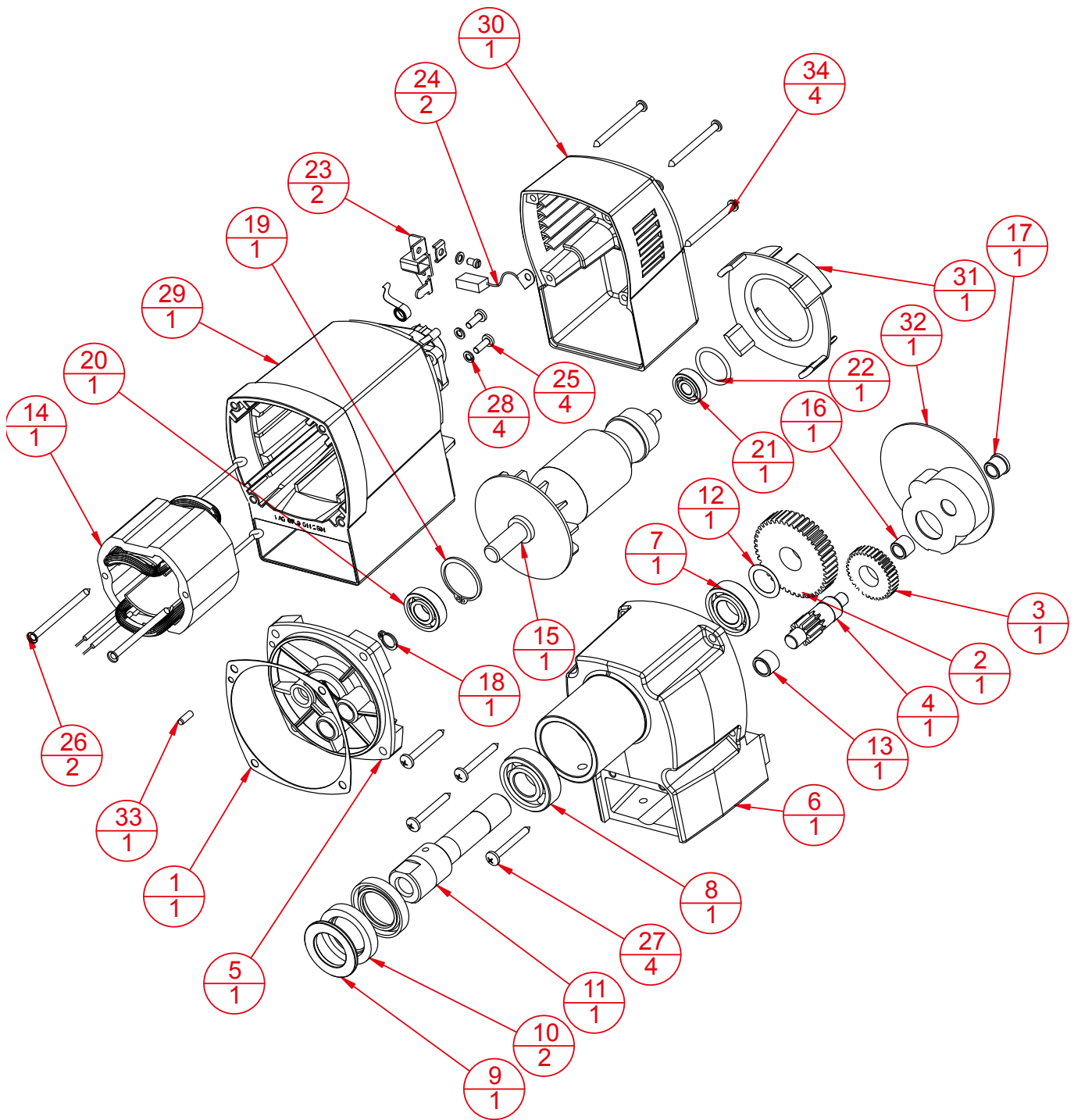



Drawing of drilling unit RS10

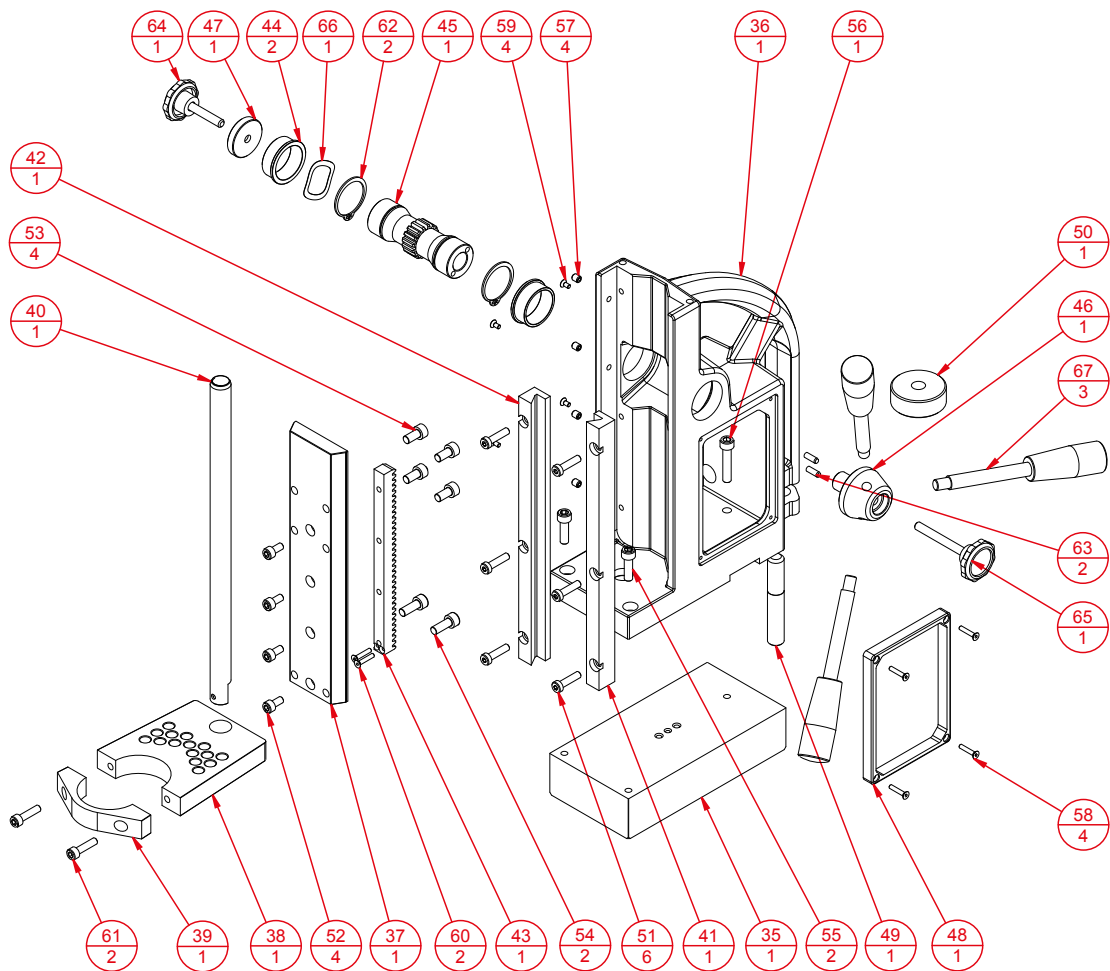

Drawing of electrical system RS10

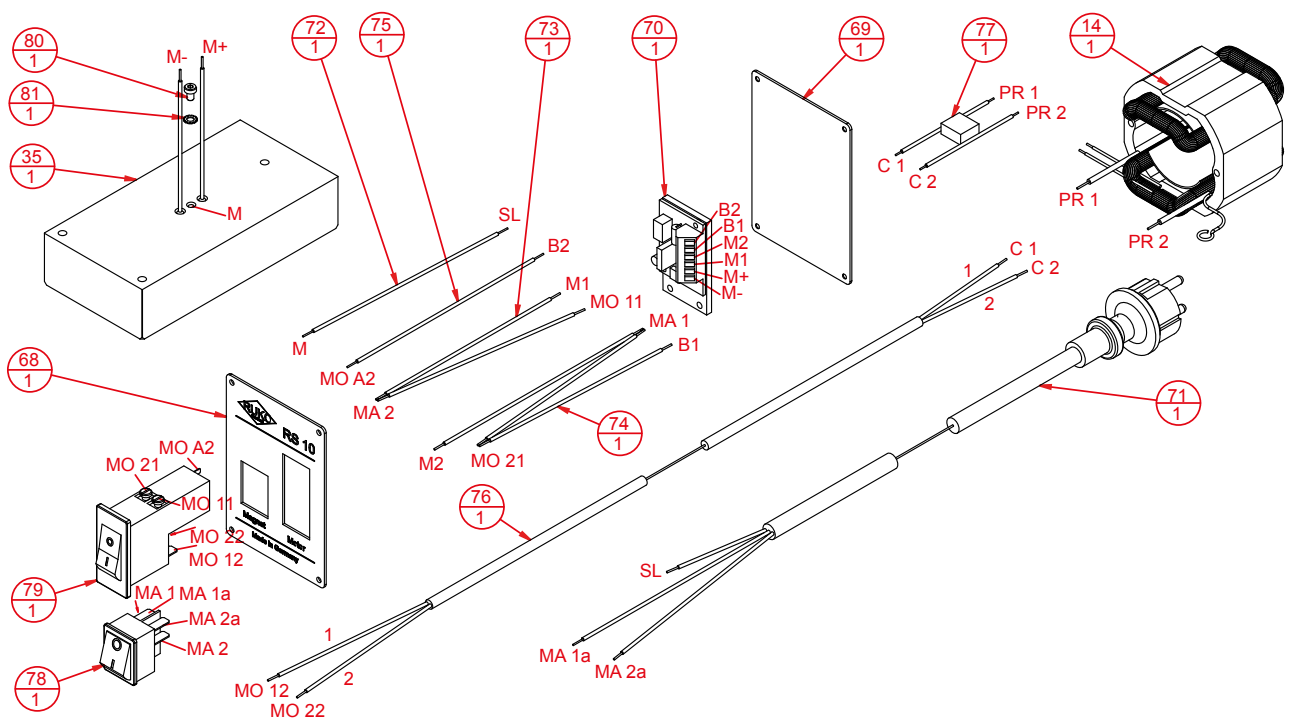



Drilling mechanism RS10

| Pos. | Description | Article no. | Quantity |
|------|---------------------------------------|-------------|----------|
| 1 | Gasket for gear box | 611 1 501 | 1 |
| 2 | Spindle wheel 43.0 x 12.0 | 611 1 502 | 1 |
| 3 | Stud wheel 34.0 x 8.0 | 611 1 503 | 1 |
| 4 | Pinion shaft | 611 1 504 | 1 |
| 5 | Gear bearing sign | 611 1 505 | 1 |
| 6 | Gear box | 611 1 506 | 1 |
| 7 | Bearing 6003-2 RS1 | 611 1 507 | 1 |
| 8 | Bearing 6203-2 RS1 | 611 1 508 | 1 |
| 9 | Conclusion plate | 611 1 514 | 1 |
| 10 | Gasket 25.0 x 40.0 x 7.0 | 611 1 515 | 2 |
| 11 | Spindle M14 | 611 1 516 | 1 |
| 12 | Adjusting washer 17.0 x 24.0 x 0.2 | 611 1 517 | 1 |
| 13 | Needle bush HK1010 | 611 1 518 | 1 |
| 14 | Pole ring | 611 1 519 | 1 |
| 15 | Rotor | 611 1 520 | 1 |
| 16 | Needle bush HK 0810 | 611 1 521 | 1 |
| 17 | Stopper | 611 1 522 | 1 |
| 18 | Safety ring DIN 471 – 10.0 x 1.0 | 611 1 523 | 1 |
| 19 | Safety ring DIN 471 – 28.0 x 1.5 | 611 1 524 | 1 |
| 20 | Ball bearing 6001-2Z | 611 1 525 | 1 |
| 21 | Ball bearing 608 2Z | 611 1 526 | 1 |
| 22 | O-ring 22.0 x 2.5 – NBR | 611 1 527 | 1 |
| 23 | Brush holder compl. | 611 1 528 | 2 |
| 24 | Carbon brush compl. 6.3 x 10.0 x 18.0 | 611 2 551 | 2 |
| 25 | Thread groove screw ZM 4.0 x 12.0 | 611 1 530 | 4 |
| 26 | Screw DIN 7981 3.9 x 60.0 | 611 1 531 | 2 |
| 27 | Screw DIN 7981 4.8 x 38.0 | 611 1 532 | 4 |
| 28 | Spring washer B4 corrugated | 611 1 533 | 4 |
| 29 | Motor casing | 611 2 501 | 1 |
| 30 | Motor cover | 611 2 502 | 1 |
| 31 | Air conduction ring | 611 2 507 | 1 |
| 32 | Grease chamber | 611 2 513 | 1 |
| 33 | Cylindrical pin DIN 7 4.0 x 12.0 | 611 3 215 | 1 |
| 34 | Screw DIN 7981 3.9 x 50.0 | 611 3 504 | 4 |

Drilling unit RS10

| Pos. | Description | Article no. | Quantity |
|------|------------------------|-------------|----------|
| 35 | Magnet | 611 1 101 | 1 |
| 36 | Solid | 611 1 300 | 1 |
| 37 | Sledge | 611 1 304 | 1 |
| 38 | Gear holder lower part | 611 1 305 | 1 |
| 39 | Gear holder top part | 611 1 306 | 1 |
| 40 | Cable pipe | 611 1 307 | 1 |
| 41 | Guide bead right | 611 1 308 | 1 |
| 42 | Guide bead left | 611 1 309 | 1 |
| 43 | Thoothed rack | 611 1 310 | 1 |
| 44 | Bearing bowl | 611 1 311 | 2 |
| 45 | Pinion shaft | 611 1 312 | 1 |
| 46 | Adapter for handle | 611 1 313 | 1 |
| 47 | Spacer | 611 1 316 | 1 |
| 48 | Front cover | 611 1 319 | 1 |
| 49 | Screw MF 12 | 611 1 330 | 1 |
| 50 | Plate MF 12 | 611 1 331 | 1 |
| 51 | DIN 7984 – M5 x 20,0 | 611 9 002 | 6 |
| 52 | DIN 912 – M5 x 10,0 | 611 9 024 | 4 |
| 54 | DIN 912 – M6 x 16,0 | 611 9 027 | 6 |
| 55 | DIN 912 – M6 x 20,0 | 611 9 028 | 2 |
| 56 | DIN 912 – M6 x 30,0 | 611 9 029 | 1 |
| 57 | DIN 913 – M5 x 6,0 | 611 9 040 | 6 |

Drilling unit RS10

| Pos. | Description | Article no. | Quantity |
|------|----------------------------------|-------------|----------|
| 58 | Screw DIN 7991 M3 x 16.0 | 611 9 059 | 4 |
| 59 | Screw DIN 7991 M3 x 8.0 | 611 9 060 | 4 |
| 60 | Screw DIN 965 M3 x 16.0 | 611 9 061 | 2 |
| 61 | DIN 912 – M5 x 20.0 | 611 9 062 | 2 |
| 62 | Safety ring DIN 471 -27.0 x 1.2 | 611 9 304 | 2 |
| 63 | Cylindrical pin DIN 7 4.0 x 12.0 | 611 9 501 | 2 |
| 64 | Handle 30.0 mm | 611 9 807 | 1 |
| 65 | Handle 50.0 mm | 611 9 808 | 1 |
| 66 | Balance plate Ø 27.0/34.0 | 611 9 812 | 1 |
| 67 | Handle M8 | 611 9 814 | 3 |

Electrical system RS10

| Pos. | Description | Article no. | Quantity |
|------|---|-------------|----------|
| 68 | Front cover | 611 1 401 | 1 |
| 69 | Back cover | 611 1 402 | 1 |
| 70 | Circuitboard | 611 1 404 | 1 |
| 71 | Main cable | 611 1 410 | 1 |
| 72 | Ground cable magnet | 611 1 411 | 1 |
| 73 | Cables motor switch-magnet switch-plate | 611 1 412 | 1 |
| 74 | Cables motor switch-magnet switch-plate-plate | 611 1 413 | 1 |
| 75 | Cable motor switch-plate | 611 1 414 | 1 |
| 76 | Motor cable | 611 1 415 | 1 |
| 77 | Cables capacitor motor RS10 / RS20 | 611 1 416 | 1 |
| 78 | Magnet switch | 611 4 402 | 1 |
| 79 | Motor switch | 611 2 573 | 1 |
| 80 | DIN 7984 – M4 x 6.0 | 611 9 016 | 1 |
| 81 | DIN 6797 – M4 | 611 9 402 | 1 |



Drawing of drilling mechanism RS25e

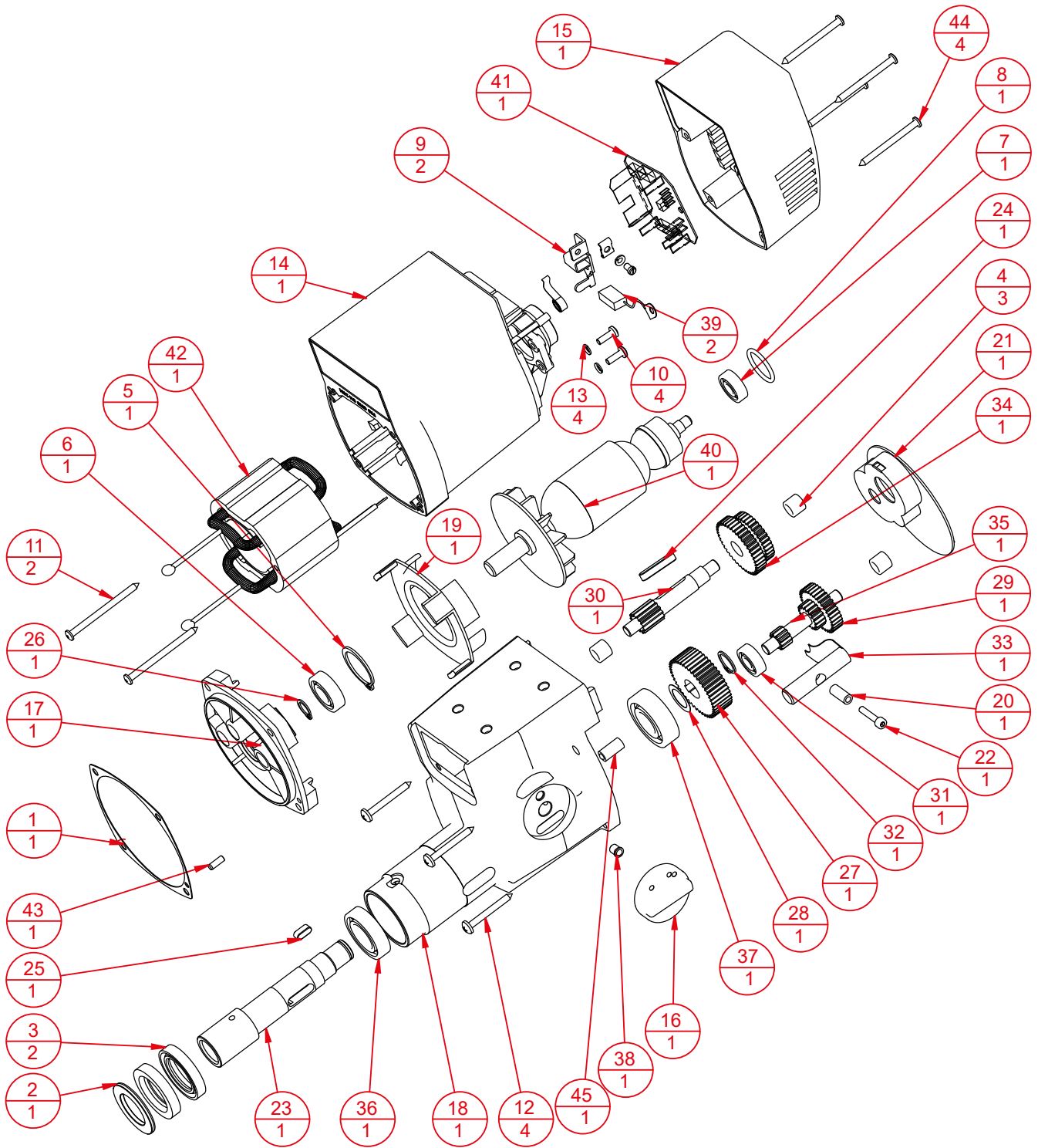



Drawing of drilling unit RS25e

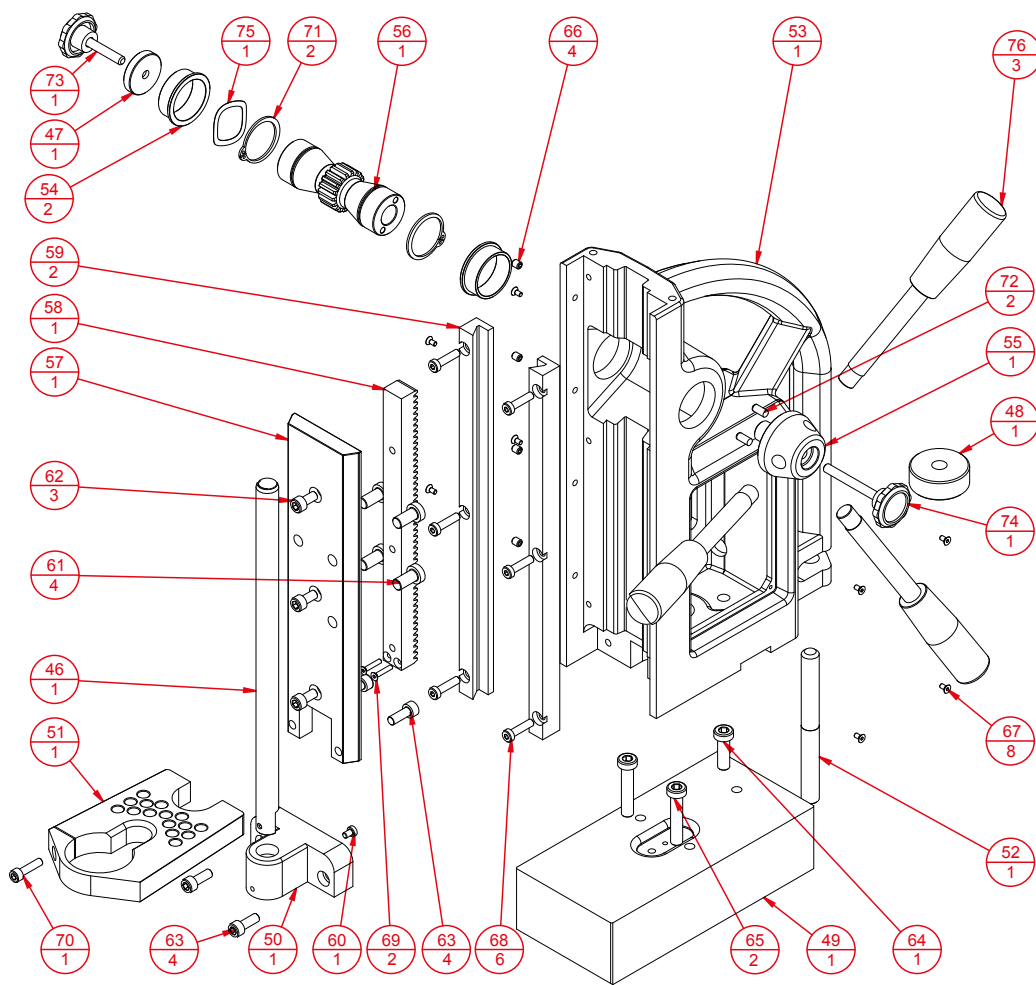

Drawing of electrical system RS25e

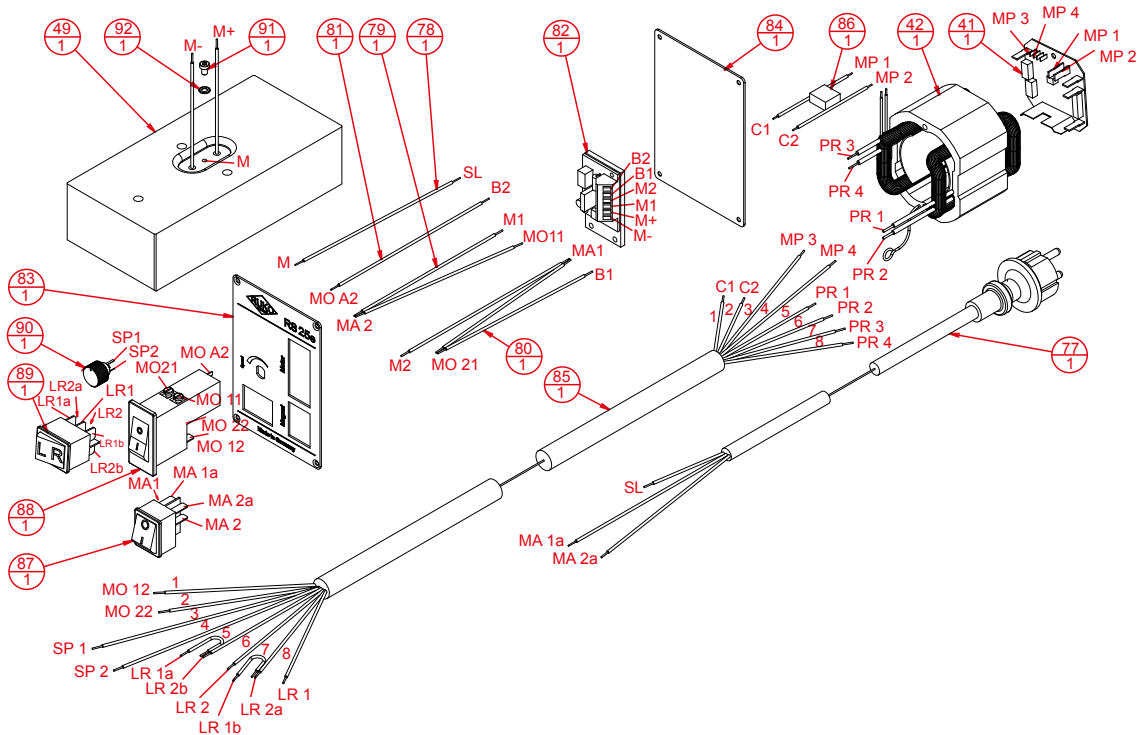



Drilling mechanism RS25e

| Pos. | Description | Article no. | Quantity |
|------|---|-------------|----------|
| 1 | Gasket for gear box | 611 1 501 | 1 |
| 2 | Conclusion plate | 611 1 514 | 1 |
| 3 | Gasket 25.0 x 40.0 x 7.0 | 611 1 515 | 2 |
| 4 | Needle bush HK 0810 | 611 1 521 | 3 |
| 5 | Safety ring DIN 471 – 28.0 x 1.5 | 611 1 524 | 1 |
| 6 | Ball bearing 6001-2Z | 611 1 525 | 1 |
| 7 | Ball bearing 608 2Z | 611 1 526 | 1 |
| 8 | O-ring 22.0 x 2.5-NBR | 611 1 527 | 1 |
| 9 | Brush holder compl. | 611 1 528 | 2 |
| 10 | Thrad groove screw Z M 4 x 12.0 | 611 1 530 | 4 |
| 11 | Screw DIN 7981 3.9 x 60.0 | 611 1 531 | 2 |
| 12 | Screw DIN 7981 4.8 x 38.0 | 611 1 532 | 4 |
| 13 | Spring washer B4 corrugated | 611 1 533 | 4 |
| 14 | Motor casing | 611 2 501 | 1 |
| 15 | Motor cover | 611 2 502 | 1 |
| 16 | Switch | 611 2 503 | 1 |
| 17 | Bearing sign | 611 2 505 | 1 |
| 18 | Gear box | 611 2 506 | 1 |
| 19 | Air conduction ring | 611 2 507 | 1 |
| 20 | Socket 4.0 x 7.0 x 16.0 | 611 2 508 | 1 |
| 21 | Grease chamber | 611 2 513 | 1 |
| 22 | Screw DIN 912 M 4 x 20.0 | 611 2 514 | 1 |
| 23 | Work spindle | 611 2 516 | 1 |
| 24 | Feather key A 5.0 x 5.0 x 28.0 | 611 2 517 | 1 |
| 25 | Feather key A 5.0 x 5.0 x 12.0 DIN 6885 | 611 2 518 | 1 |
| 26 | Safety ring DIN 471 – 11.0 x 1.0 | 611 2 519 | 1 |
| 27 | Spindle wheel 45 Z | 611 2 520 | 1 |
| 28 | Feather key 15.0 x 22.0 x 0.2 | 611 2 521 | 1 |
| 29 | Stud wheel 34 Z | 611 2 522 | 1 |
| 30 | Shaft for cluster gear 13 Z | 611 2 523 | 1 |
| 31 | Groove ball bearing SKF 608 | 611 2 524 | 1 |
| 32 | Safety ring DIN 471 – 15.0 x 1.0 | 611 2 525 | 1 |
| 33 | Coupling pin | 611 2 526 | 1 |
| 34 | Cluster gear 34/40 Z | 611 2 527 | 1 |
| 35 | Shaft with 2 pinion | 611 2 528 | 1 |
| 36 | Groove ball bearing SKF 61904-2 RS1 | 611 2 529 | 1 |
| 37 | Groove ball bearing SKF 6203-2 RS1 | 611 2 530 | 1 |
| 38 | Pressure device 6.0 x 7.0 | 611 2 531 | 1 |
| 39 | Carbon brush RS25e | 611 2 551 | 2 |
| 40 | Rotor | 611 2 552 | 1 |
| 41 | Circuitboard | 611 2 553 | 1 |
| 42 | Pole ring | 611 2 554 | 1 |
| 43 | Cylindrical pin DIN 7 4.0 x 12.0 | 611 3 215 | 1 |
| 44 | Screw DIN 7981 3.9 x 50.0 | 611 3 504 | 4 |
| 45 | Spring pressure device M 8 x 16.0 | 611 3 520 | 1 |

Drilling unit RS25e

| Pos. | Description | Article no. | Quantity |
|------|---------------------|-------------|----------|
| 46 | Cable pipe | 611 1 307 | 1 |
| 47 | Spacer | 611 1 316 | 1 |
| 48 | Plate MF 12 | 611 1 331 | 1 |
| 49 | Magnet | 611 2 101 | 1 |
| 50 | Prop for cable pipe | 611 2 210 | 1 |
| 51 | Gear holder | 611 2 223 | 1 |
| 52 | Screw MF 12 | 611 2 226 | 1 |
| 53 | Solid | 611 3 200 | 1 |
| 54 | Bearing bowl | 611 3 212 | 2 |
| 55 | Adapter for handle | 611 3 216 | 1 |
| 56 | Pinion shaft | 611 3 217 | 1 |
| 57 | Sledge | 611 3 219 | 1 |
| 58 | Toothed rack | 611 3 222 | 1 |

Drilling unit RS25e

| Pos. | Description | Article no. | Quantity |
|------|----------------------------------|-------------|----------|
| 59 | Guide bead | 611 3 228 | 2 |
| 60 | DIN 7984 – M4 x 6.0 | 611 9 016 | 1 |
| 61 | DIN 7984 – M8 x 16.0 | 611 9 020 | 4 |
| 62 | DIN 912 – M6 x 12.0 | 611 9 026 | 3 |
| 63 | DIN 912 – M6 x 16.0 | 611 9 027 | 4 |
| 64 | DIN 912 – M8 x 25.0 | 611 9 032 | 1 |
| 65 | DIN 912 – M8 x 40.0 | 611 9 034 | 2 |
| 66 | DIN 913 – M5 x 6.0 | 611 9 040 | 4 |
| 67 | DIN 7991 – M3 x 8.0 | 611 9 045 | 8 |
| 68 | DIN 7984 – M5 x 20.0 | 611 9 052 | 6 |
| 69 | DIN 965 – M4 x 16.0 | 611 9 059 | 2 |
| 70 | DIN 912 – M5 x 20.0 | 611 9 062 | 1 |
| 71 | Safety ring DIN 471 – 30.0 x 1.5 | 611 9 306 | 2 |
| 72 | Cylindrical pin DIN 7 5.0 x 12.0 | 611 9 510 | 2 |
| 73 | Handle 30.0 mm | 611 9 807 | 1 |
| 74 | Handle 50.0 mm | 611 9 808 | 1 |
| 75 | Balance plate Ø 30.0/36.0 | 611 9 813 | 1 |
| 76 | Handle M12 | 611 9 815 | 3 |

Electrical system RS25e

| Pos. | Description | Article no. | Quantity |
|------|---|-------------|----------|
| 77 | Main cable | 611 1 410 | 1 |
| 78 | Ground cable magnet | 611 1 411 | 1 |
| 79 | Cables motor switch-magnet switch-plate | 611 1 412 | 1 |
| 80 | Cables motor switch-magnet switch-plate-plate | 611 1 413 | 1 |
| 81 | Cables motor switch-plate | 611 1 414 | 1 |
| 82 | Circuitboard | 611 2 404 | 1 |
| 83 | Front cover RS25e | 611 2 405 | 1 |
| 84 | Back cover RS25e | 611 2 406 | 1 |
| 85 | Motor cable RS25e | 611 2 420 | 1 |
| 86 | Cables capacitor motor RS25e | 611 3 416 | 1 |
| 87 | Magnet switch | 611 4 402 | 1 |
| 88 | Motor switch | 611 2 573 | 1 |
| 89 | Switch clockwise - counterclockwise | 611 4 404 | 1 |
| 90 | Resistance for recolon | 611 4 405 | 1 |
| 91 | DIN 7984 - M4 x 6 | 611 9 016 | 1 |
| 92 | DIN 6797 - M4 | 611 9 402 | 1 |



Drawing of drilling mechanism RS40e

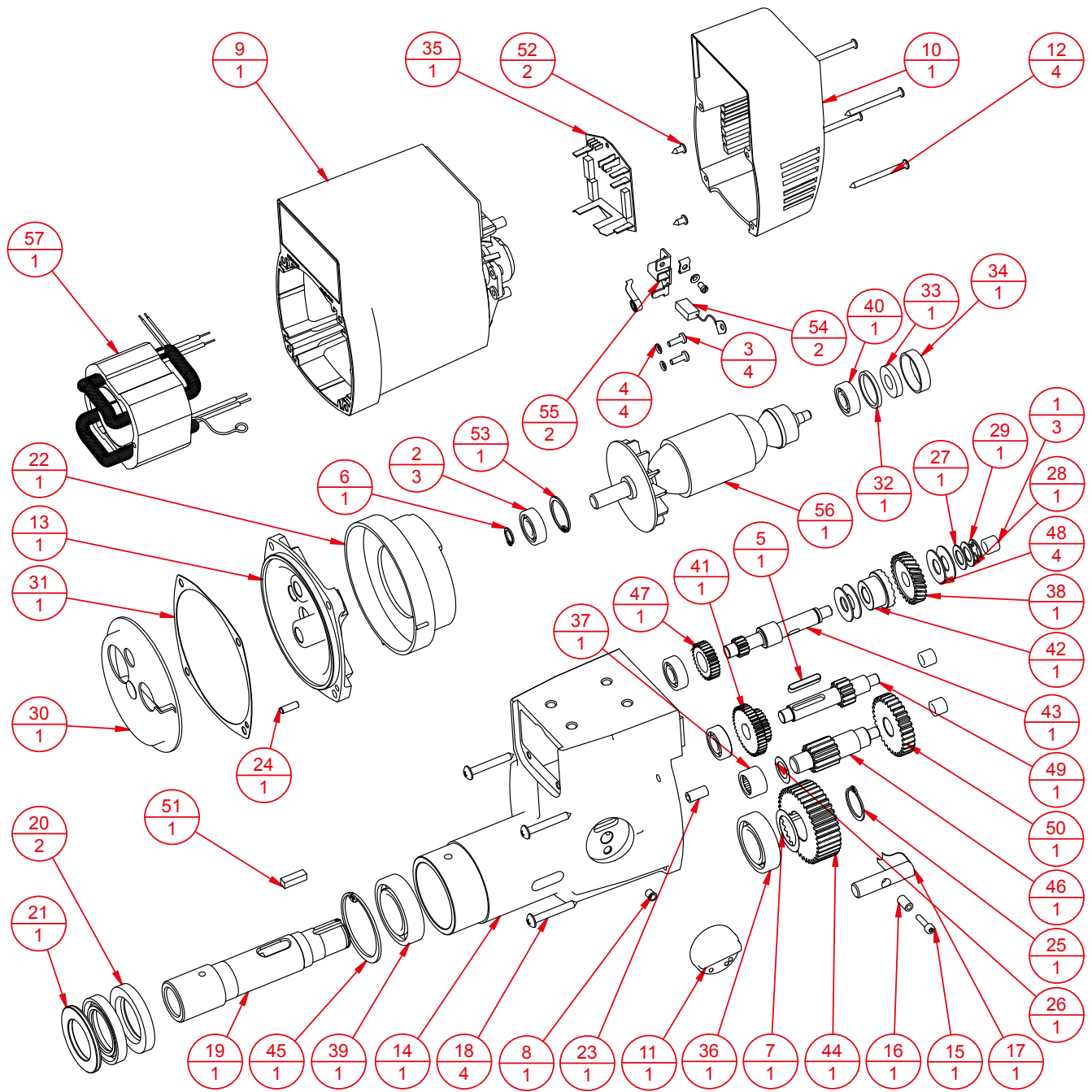



Drawing of drilling unit RS40e

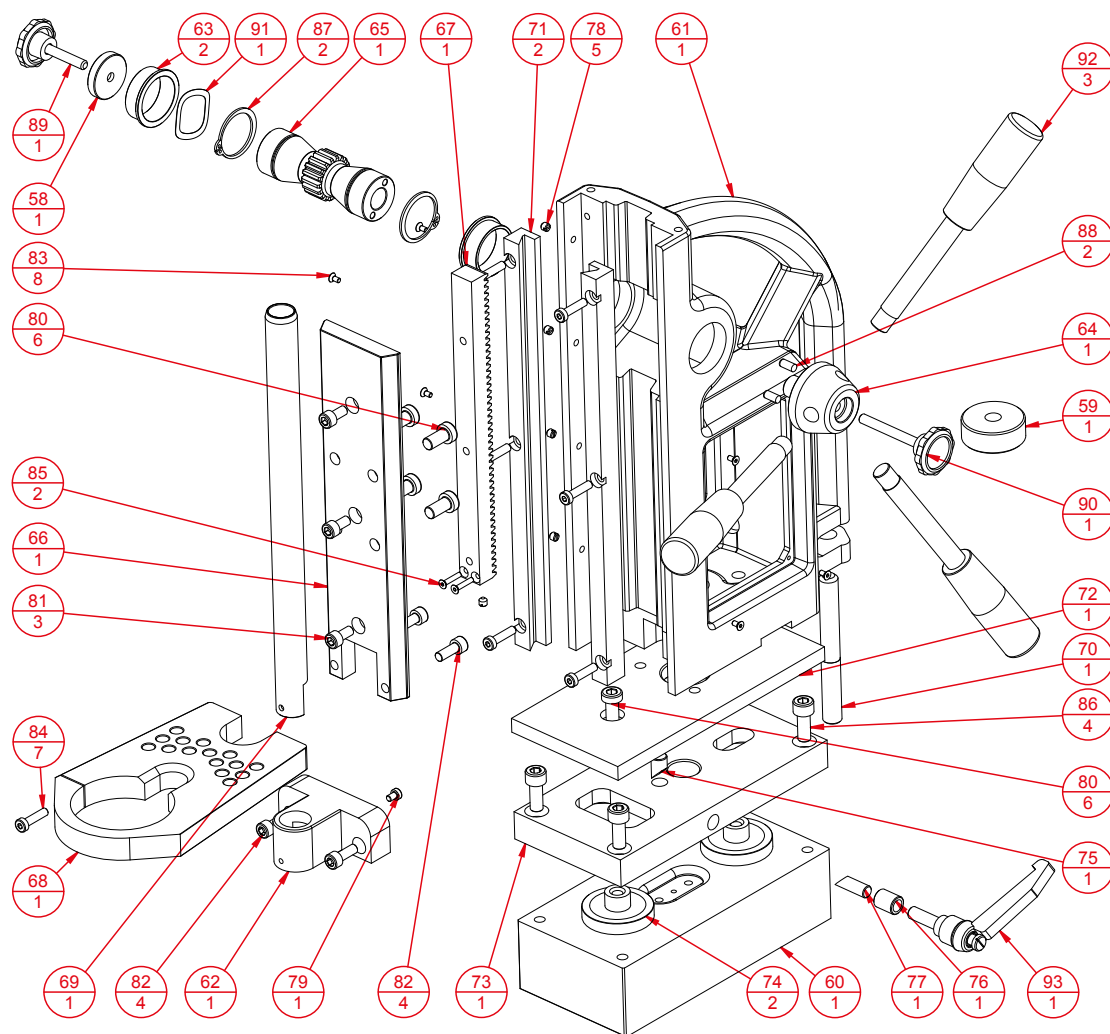

Drawing of electrical system RS40e

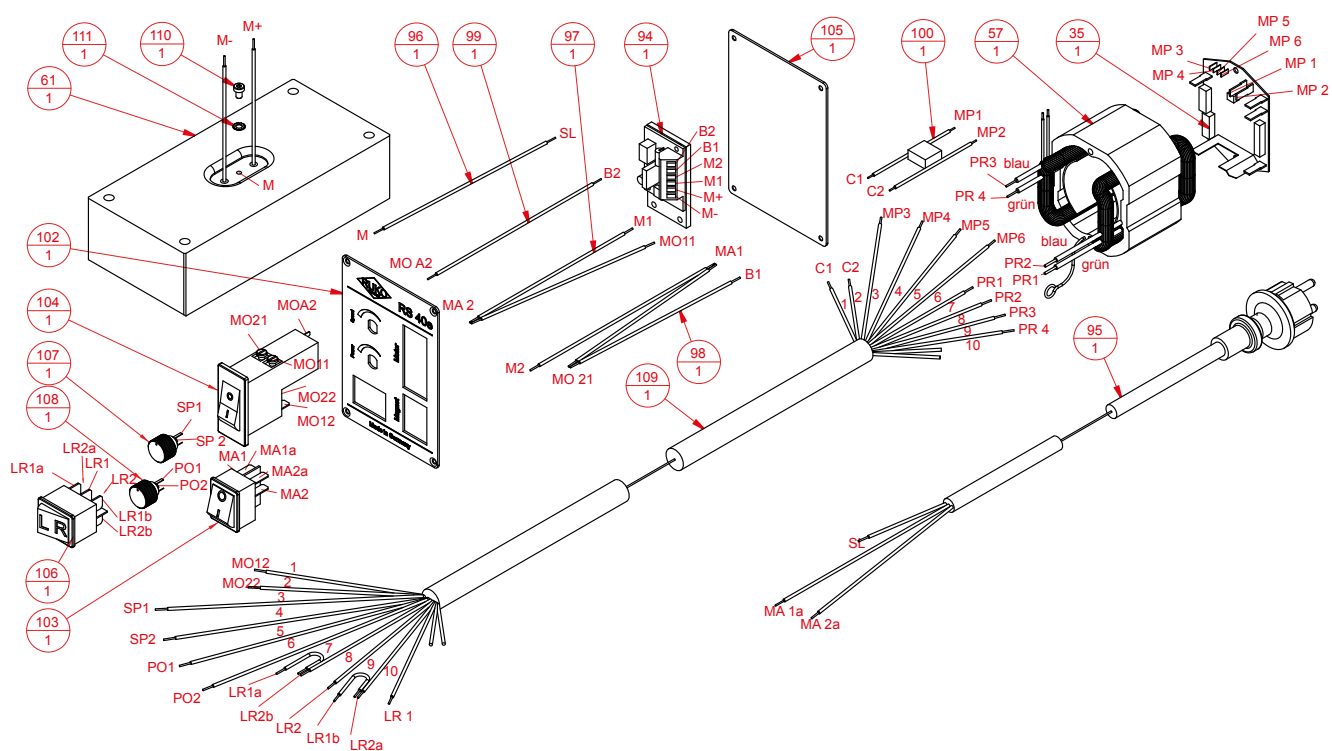



Drilling mechanism RS40e

| Pos. | Description | Article no. | Quantity |
|------|------------------------------------|-------------|----------|
| 1 | Needle bush HK 0810 | 611 1 521 | 3 |
| 2 | Ball bearing 6001 – 2Z | 611 1 525 | 3 |
| 3 | Thread groove screw Z M4 x 12.0 | 611 1 530 | 4 |
| 4 | Spring washer B4 corrugated | 611 1 533 | 4 |
| 5 | Feather key A 5.0 x 5.0 x 28.0 | 611 2 517 | 1 |
| 6 | Safety ring DIN 471 – 11.0 x 1.0 | 611 2 519 | 1 |
| 7 | Feather key 15.0 x 22.0 x 0.2 | 611 2 521 | 1 |
| 8 | Pressure device 6.0 x 7.0 | 611 2 531 | 1 |
| 9 | Motor casing | 611 3 501 | 1 |
| 10 | Motor cover | 611 3 502 | 1 |
| 11 | Button | 611 3 503 | 1 |
| 12 | Screw DIN 7981 3.9 x 50.0 | 611 3 504 | 4 |
| 13 | Bearing sign | 611 3 505 | 1 |
| 14 | Gear box | 611 3 506 | 1 |
| 15 | Scew DIN 912 – M4 x 16.0 | 611 3 507 | 1 |
| 16 | Socket 7.0 x 4.0 x 12.0 | 611 3 508 | 1 |
| 17 | Coupling pin | 611 3 509 | 1 |
| 18 | Screw DIN 7981 – 5.5 x 40.0 | 611 3 512 | 4 |
| 19 | Work spindle Morse taper 3 | 611 3 516 | 1 |
| 20 | Gasket 34.0 x 55.0 x 8.0 DIN 3760 | 611 3 517 | 2 |
| 21 | Conclusion plate 55.0 x 34.1 x 6.0 | 611 3 518 | 1 |
| 22 | Air conduction ring | 611 3 519 | 1 |
| 23 | Spring pressure device M8 x 16.0 | 611 3 520 | 1 |
| 24 | Cylindrical pin DIN 7 5.0 x 16.0 | 611 3 523 | 1 |
| 25 | Safety ring DIN 471 – 24.0 x 1.2 | 611 3 524 | 1 |
| 26 | Palte for needle bearing | 611 3 525 | 1 |
| 27 | Pressure plate 1 | 611 3 526 | 1 |
| 28 | Pressure plate 2 | 611 3 527 | 1 |
| 29 | Safety ring 9x1 DIN 6799 | 611 3 528 | 1 |
| 30 | Grease chamber | 611 3 529 | 1 |
| 31 | Gasket for gear box | 611 3 530 | 1 |
| 32 | Plate | 611 3 533 | 1 |
| 33 | Ring magnet | 611 3 534 | 1 |
| 34 | Bearing cover | 611 3 535 | 1 |
| 35 | Circuitboard | 611 4 533 | 1 |
| 36 | Groove ball bearing 6005 2 RS | 611 3 537 | 1 |
| 37 | Needle bearing RNA 4900 | 611 3 538 | 1 |
| 38 | Coupling disk | 611 4 539 | 1 |
| 39 | Groove ball bearing 6006 2 RS | 611 3 540 | 1 |
| 40 | Grove ball bearing 6000 2Z | 611 3 541 | 1 |
| 41 | Cluster gear 39/25 Z | 611 3 542 | 1 |
| 42 | Coupling half | 611 3 544 | 1 |
| 43 | Intermediate shaft 1 13 Z | 611 3 545 | 1 |
| 44 | Spindle wheel | 611 3 546 | 1 |
| 45 | Safety ring DIN 472 – 55.0 x 2.0 | 611 3 547 | 1 |
| 46 | Intermediate shaft 3 12 Z | 611 3 548 | 1 |
| 47 | Stud wheel 1 28 Z | 611 3 549 | 1 |
| 48 | Disk spring 28.0 x 12.2 x 1.0 | 611 3 550 | 4 |
| 49 | Intermediate shaft 2 12 Z | 611 3 551 | 1 |
| 50 | Stud wheel 2 31 Z | 611 3 552 | 1 |
| 51 | Feather key B 6.0 x 6.0 x 20.0 | 611 3 553 | 1 |
| 52 | Sheet metal screw HF 3.9 x 9.5 | 611 3 554 | 2 |
| 53 | Safety ring DIN 472 – 28.0 x 1.2 | 611 3 555 | 1 |
| 54 | Carbon brush | 611 4 556 | 2 |
| 55 | Brush holder compl. | 611 3 557 | 2 |
| 56 | Rotor | 611 4 531 | 1 |
| 57 | Pol ring | 611 4 532 | 1 |

Drilling unit RS40e

| Pos. | Description | Article no. | Quantity |
|------|----------------------------------|-------------|----------|
| 58 | Spacer | 611 1 316 | 1 |
| 59 | Plate MF12 | 611 1 331 | 1 |
| 60 | Magnet | 611 2 101 | 1 |
| 61 | Solid | 611 2 200 | 1 |
| 62 | Prop for cable pipe | 611 3 210 | 1 |
| 63 | Bearing bowl | 611 3 212 | 2 |
| 64 | Adapter for handle | 611 3 216 | 1 |
| 65 | Pinion shaft | 611 3 217 | 1 |
| 66 | Sledge | 611 3 219 | 1 |
| 67 | Toothed rack | 611 3 222 | 1 |
| 68 | Gear holder | 611 3 223 | 1 |
| 69 | Cable pipe | 611 3 224 | 1 |
| 70 | Screw MF12 | 611 3 226 | 1 |
| 71 | Guide bead | 611 3 228 | 2 |
| 72 | Intermediate plate top | 611 3 251 | 1 |
| 73 | Intermediate plate bottom | 611 3 252 | 1 |
| 74 | Gliding plate | 611 3 253 | 2 |
| 75 | Pressure bolt | 611 3 254 | 1 |
| 76 | Thread liner | 611 9 823 | 1 |
| 77 | Pressure pin | 611 3 256 | 1 |
| 78 | Set screw DIN 913 – M5 x 6.0 | 611 9 001 | 5 |
| 79 | DIN 7984 – M4 x 6.0 | 611 9 016 | 1 |
| 80 | DIN 7984 – M8 x 16.0 | 611 9 020 | 6 |
| 81 | DIN 912 – M6 x 12.0 | 611 9 026 | 5 |
| 82 | DIN 912 – M6 x 16.0 | 611 9 027 | 4 |
| 83 | DIN 7991 – M3 x 8.0 | 611 9 045 | 8 |
| 84 | DIN 7984 – M5 x 20.0 | 611 9 052 | 7 |
| 85 | DIN 965 – M4 x 16.0 | 611 9 059 | 2 |
| 86 | DIN 912 – M8 x 20.0 | 611 9 063 | 4 |
| 87 | Safety ring DIN 471 – 30.0 x 1.5 | 611 9 306 | 2 |
| 88 | Cylindrical pin DIN 7 5.0 x 12.0 | 611 9 510 | 2 |
| 89 | Handle 30.0 mm | 611 9 807 | 1 |
| 90 | Handle 50.0 mm | 611 9 808 | 1 |
| 91 | Balance plate Ø 30.0/36.0 | 611 9 813 | 1 |
| 92 | Handle M12 | 611 9 815 | 3 |
| 93 | Clamping handle | 611 9 816 | 1 |

Electrical system RS40e

| Pos. | Description | Article no. | Quantity |
|------|---|-------------|----------|
| 94 | Circuitboard | 611 2 404 | 1 |
| 95 | Main cable | 611 1 410 | 1 |
| 96 | Ground cable magnet | 611 1 411 | 1 |
| 97 | Cables motor switch-magnet switch-plate | 611 1 412 | 1 |
| 98 | Cables motor switch-magnet switch-plate-plate | 611 1 413 | 1 |
| 99 | Cables motor swittch-plate | 611 1 414 | 1 |
| 100 | Cables capacitor motor | 611 3 416 | 1 |
| 102 | Front cover | 611 4 401 | 1 |
| 103 | Magnet switch | 611 4 402 | 1 |
| 104 | Motor switch | 611 2 573 | 1 |
| 105 | Back cover | 611 4 408 | 1 |
| 106 | Switch clockwise - counterclockwise | 611 4 404 | 1 |
| 107 | Resistance for revolution | 611 4 405 | 1 |
| 108 | Resistance for torque | 611 4 406 | 1 |
| 109 | Motor cable | 611 4 415 | 1 |
| 110 | DIN 7984 – M4 x 6.0 | 611 9 016 | 1 |
| 111 | DIN 6797 – M4 | 611 9 402 | 1 |

Connection diagramm RS10, RS25e, RS40e

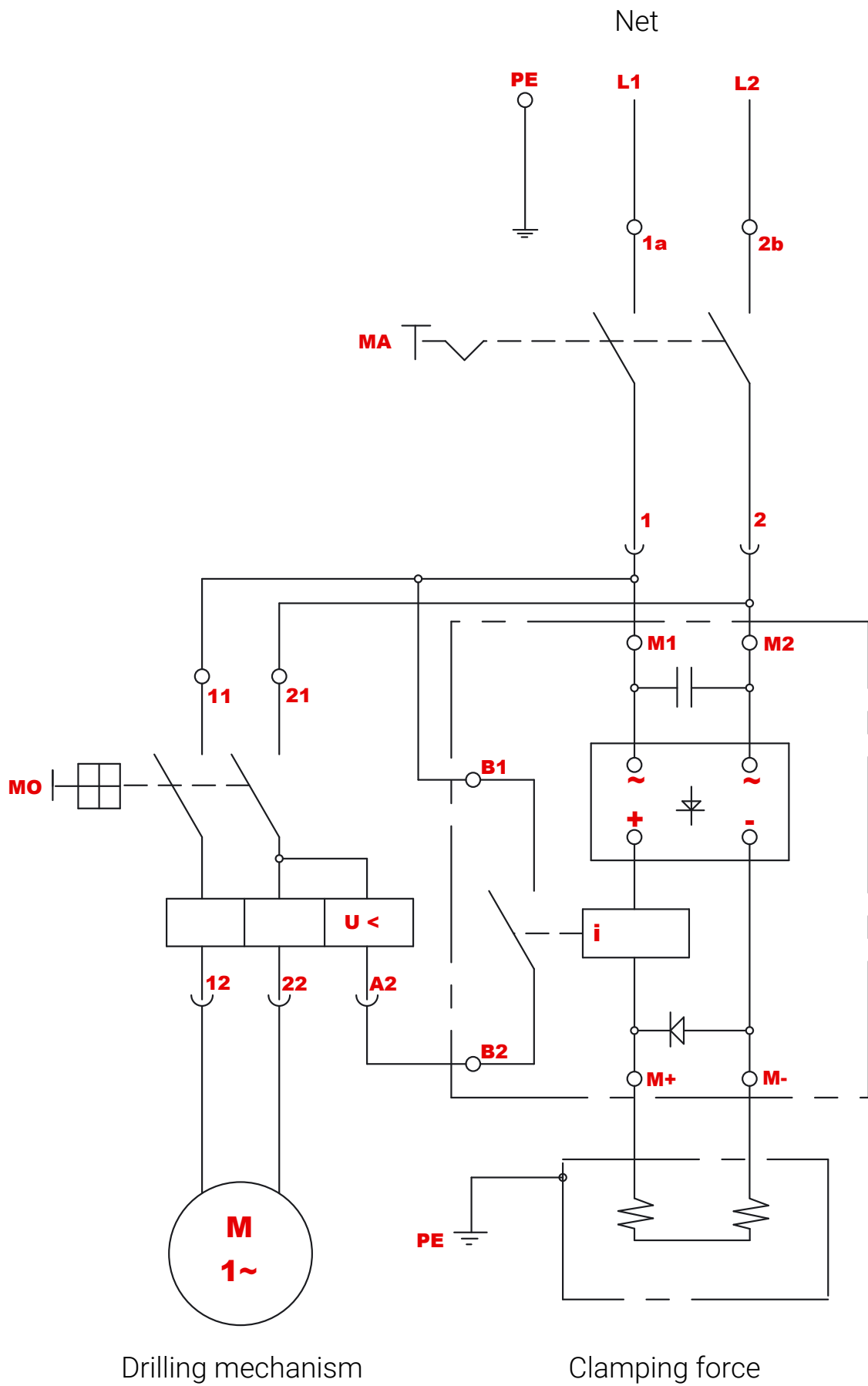



Guarantee:

The Manufacturer default warranty period is 12 months after date of delivery. Proof is the invoice.
Condition is that the machine has been used, maintained and cleaned correctly and that no repairs by others have been made.
The guarantee is limited to repairs free of charge or replacements of the damaged parts that are caused by material defects or production faults.

Parts that have been damaged by normal wear or repairs made by oneself or others are not subject to this guarantee.
This guarantee is only valid if the correct tools, original accessories and spare parts have been used.

All other claims are excluded, i.e. RUKO is not liable for direct or indirect defects, damages caused by defects, losses or costs that may arise from the use or the impossibility to use the machine for a certain purpose.

Tacit assurances concerning the use or aptability for a certain purpose are not possible. If a defect is noted the machine has to be sent to RUKO GmbH as quickly as possible for repair. All earlier verbal or written guarantee declarations are replaced by the above mentioned guarantee.

Declaration of conformity:

We declare in sole responsibility that the product sold by us is in accordance with the following technical norms or normative documents:

EN 55014 - 1: 2001
EN 55014 - 2: 1997
EN 60204 - 1: 1998
EN 61000 - 3 - 2 / 3

according to the regulations stipulated in the directives 89 / 336 / EWG (rather EMVG)
73 / 23 / EWG (Low Voltage Directive),
98 / 37 / EG (Machine Directive)

The description of operation is described in the operation instructions.

Josef Ruppert
Management

RUKO GmbH Precision tools, Robert-Bosch-Straße 7-11, D-71088 Holzgerlingen, Germany



RUKO GmbH PRECISION TOOLS

Robert-Bosch-Straße 7-11
71088 Holzgerlingen
Germany

Tel.: +49(0)7031 / 6800-0
Internet: www.ruko.de
E-Mail: info@ruko.de

Export sales
Tel.: +49(0)7031 / 6800-54 / 84 / 85 / 790
Fax: +49(0)7031 / 6800-21 / 66

© All rights reserved.

This catalogue is protected by copyright law and remains solely our property.
We reserve the right to make changes to technical data. Images are non-binding.
Liability for printing errors is excluded.
This catalogue invalidates any previous editions.

No. 810 431 / 16 1. Edition October 2016
english