

1	6011113	Frame 4 holes - 4 fixing screws
1A	6011112	Frame 4 holes - 6 fixing screws
1B	6011111	Frame 4 holes - notched
2	6010011	Screw M6x16
3	6010021	Spring washer 6.3
4	6010031	Hex nut M5
5	6010041	Adjusting screw M5
6	6011132	Magnet 4 holes (indicator option) - from of 01.06.2005
6A	6011131	Magnet 4 holes (indicator option)
6B	6010051	Magnet 4 holes (w/o indicator)
6C	6010050	Magnet universal (w/o indicator)
7	6010061	Magnet indicator
8	6010073	Slide unsymmetrical L:253 mm, B:80 mm, hole distance 66 mm
8A	6010072	Slide unsymmetrical L:253 mm, B:80 mm, hole distance 40 mm
8B	6010071	Slide symmetrical L:253 mmm B:80 mm, hole distance 40 mm
8C		Slide (up to 1995) cannot be delivered anymore
9	6010081	Rack
10	6010091	Screw M6x20
11	6010102	Motor holder - hole distance 66 mm
11A	6010101	Motor holder - hole distance 40 mm
12	6010111	Screw M6x25
13	6010121	Motor fixing plate
14	6010131	Arbor support
15	6010142	Spindle 1/2"x20NF - 19 mm Weldon - 112 mm
15A	6010141	Spindle 1/2"x20NF - 19 mm Weldon - 103 mm
16	6010151	Spring, washer, button
17	6010161	Spring washer 19x1.0
18	6010172	Ring for coolant sytem (quick connect)
18A	6010171	Ring for coolant system (hose diam 6 mm)
19	6010181	Allen screw M8x8
20	6011191	Guide strip (r/l) L:249 mm, glued
20A	6010192	Guide strip (r/l) L:249 mm, notched
20B	6010191	Guide strip (r/l), holes
21	6010202	Guide strip brass (right) L:249, 4 screws
21A	6011201	Guide strip brass (right) L:249, 6 fixing screws
21B	6010201	Guide strip steel (right), L:249
22	6010210	Capstan
23	6010221	Plate for capstan
24	6010231	Screw for capstan
25	6010241	Handle
26	7010001	Cable protection hose
27	7010021	Cable protection PG9
28	7010031	Cable protection PG11
29	7010041	Main cable 220-240 V (European plug)
29A	7010411	Main cable 220-240 V (English plug)
29B	7010051	Main cable 110 V
30	7010061	Earthing
31	7011241	Rear plate
32	7010081	Screw for rear plate M4x6
33	7010231	Front plate

FE 32

34	7010101	Led-light for indicator
35	7010111	On/off switch motor
36	7010121	Fuse holder
37	7010131	Fuse 2A, 5x20 250 V F, DIN 41 661
38	7010141	On/off switch magnet
39	7010153	Control unit 230 V, 3 relays, from of 01.06.2005
39A	7010152	Control unit 230 V, 3 relays
39B	7010163	Control unit 110V, 3 relays, from of 01.06.2005
39C	7010162	Control unit 110V, 3 relays
40	7010971	Strain relief
41	5002001	Motor unit complete 230V
41A	5002101	Motor unit complete 110V

FE 32

FE 32 - housing

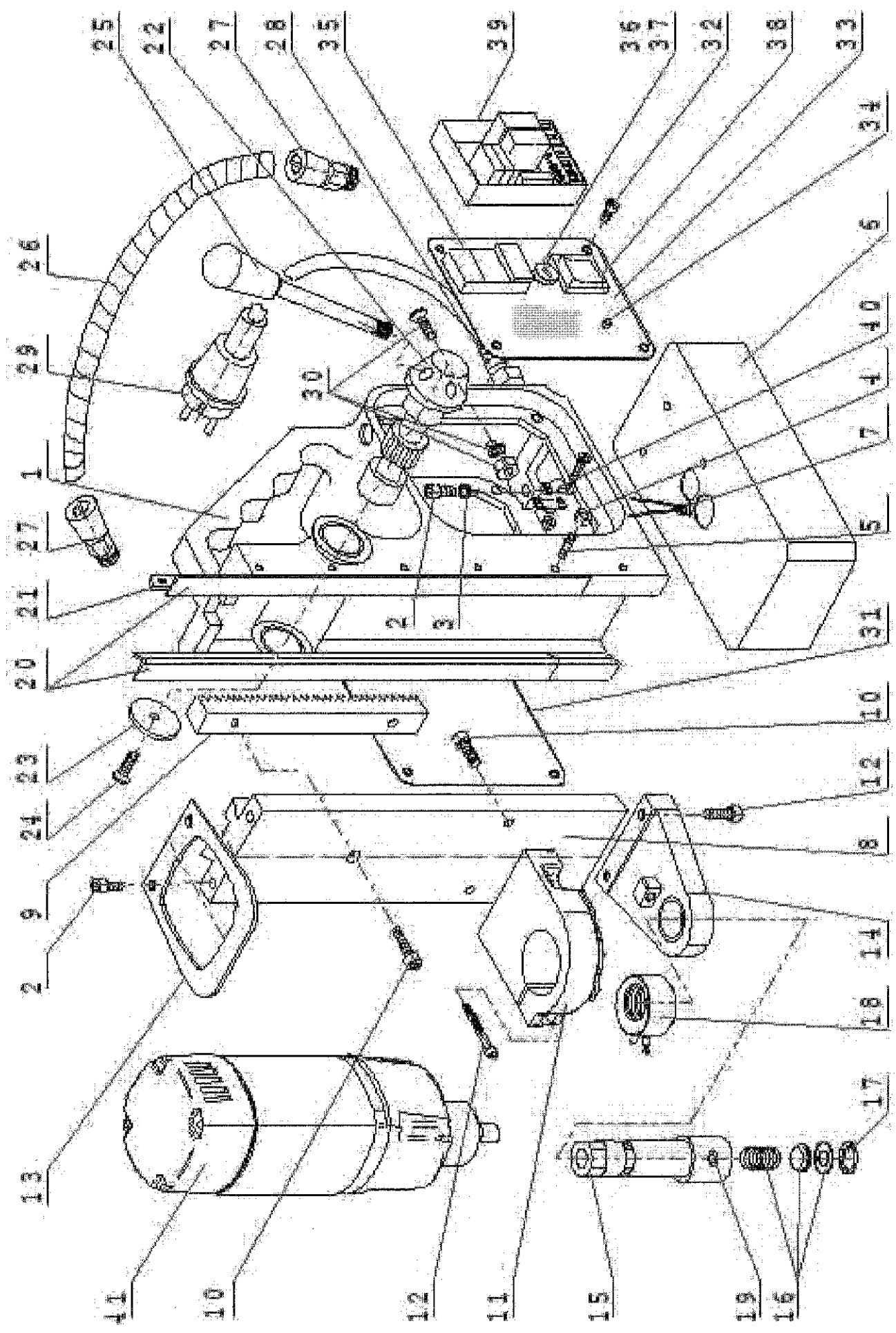

Motor unit FE 32

- 1 5010001 spring bolt
- 2 5010011 Wire from spring
- 3 5010021 Screw 4.2x13
- 4 5010031 Screw 3.9x60
- 5 5010041 Washer 16x22x0.5
- 6 5010051 Washer 17x24x0.2
- 7 5010061 Ball bearing 608 2Z
- 8 5010071 Ball bearing 608
- 9 5010091 Ball bearing 6001 2Z
- 10 5010091 Spindle gear 40T
- 11 5010101 Middle gear 34T
- 12 5010111 Spindle drive shaft
- 13 5010121 Pinion shaft 8T
- 14 5010131 Capacitor receptors
- 15 5010141 Carbon brush 6.3x10.20
- 16 5010151 Field 220-240 V
- 16A 5010161 Field 110 V
- 17 5010171 Armature 220-240 V
- 17A 5010181 Armature 110 V
- 18 5010191 Motor cover
- 19 5010201 Motor housing (black)
- 20 5010211 Gearbox
- 21 5010221 Screw 4.8x40
- 22 5010231 Screw 4.8x50
- 23 5010241 Ball bearing 6003 2RS
- 24 5010251 Air guide
- 25 5010261 Circlip 10/1
- 26 5010271 Circlip 28/1,2
- 27 5010281 Gearbox cover
- 28 5010291 Connector pin 4x12

FE 32 - motor unit

